

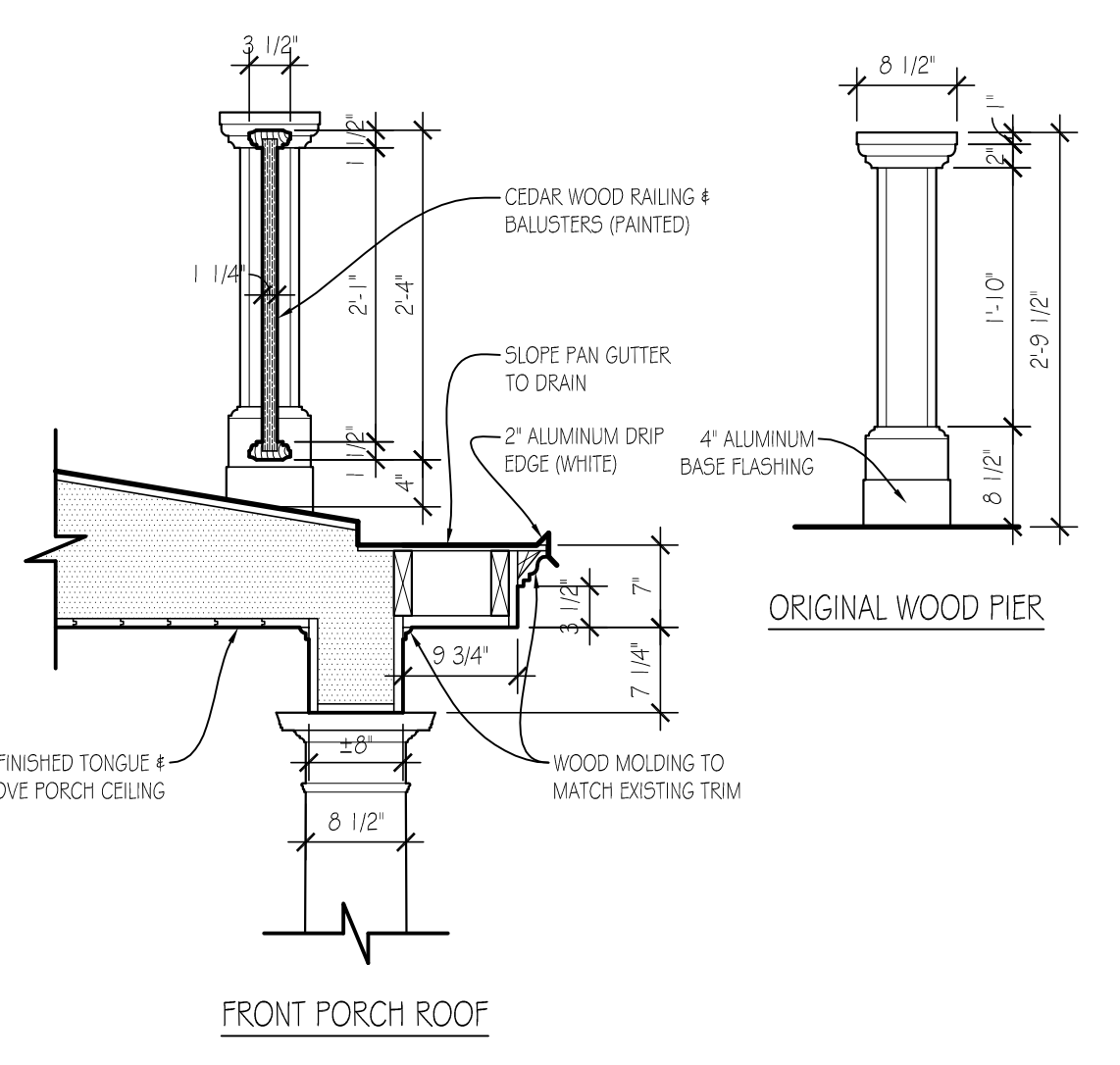

1 FRONT ELEVATION - YORK COURT
 ELEV. SCALE: 1/4" = 1'-0"



2 REAR ELEVATION - YORK COURT
 ELEV. SCALE: 1/4" = 1'-0"



FRONT PORCH ROOF

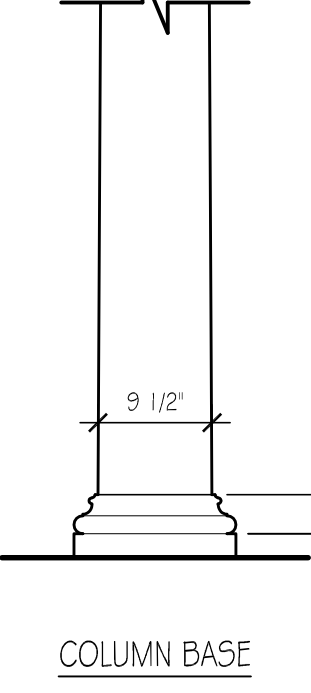

COLUMN BASE

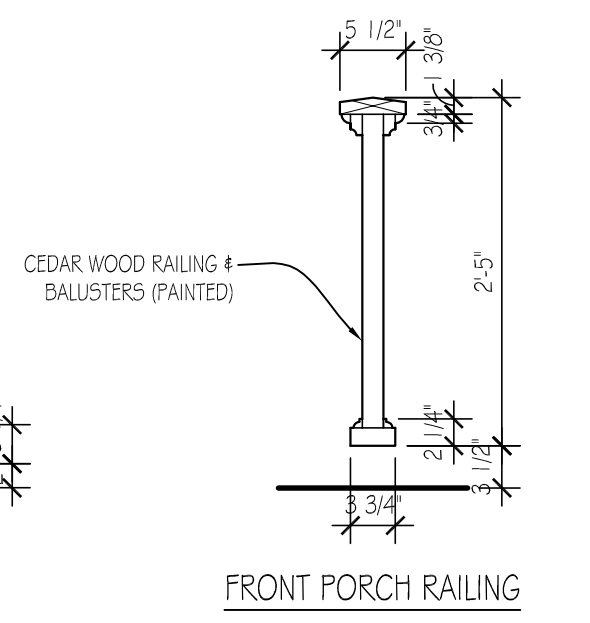

FRONT PORCH RAILING

3 DETAIL: HISTORIC WOOD RAILINGS
 ELEV. SCALE: 3/4" = 1'-0"

GUILFORD ARCHITECTURAL COMMITTEE
 YORK COURT PATTERN BOOK